

PSH 15/1 piezo mirror tilting system

- ◆ 15mrad tilting angle
- ◆ high step resolution
- ◆ excellent guidance accuracy
- ◆ +/- tilting
- ◆ 1" mirror mounting area
- ◆ μ rad-resolution

application:

- high resolution mirror tilting system for precision beam alignment
- for applications in fields of optics, laser technology, lithography, metrology and printing industry



PSH 15/1

Design

The mirror tilting system of the series PSH has been developed for the fast and precise positioning of optical mirrors.

Despite a total tilting range of 15mrad the system provides max. position resolution of $<0.03\mu$ rad.

The FEM-calculated, on the approved nanoX-design based System, has been especially developed for 1"-components.

The drive sections in the monolithic solid state flexure hinges design generate motion without any play. So settling times in the ms range can be guaranteed with this system.

Due to the special actuator parallel kinematics, nanoX Design, best possible data in terms of guidance accuracy can be achieved.

Applications for this series are for high resolution positioning of components, as scanning stage in optical applications and laser technology.

Specials

The sophisticated gear design of the series nanoSX and nanoX® developed by **piezosystem jena** with bi-directional actuation design features an active push/pull-force.

Basic feature of these high performance piezo actuators is the very high stiffness and the resonance frequency. So even high loads can be moved in a highly dynamic manner.

The overshooting behavior is actively minimized by controllable set and reset-forces.

Defined positions can be approached with nanometer accuracy even with full load when the actuator is equipped with a measurement system. This is a very substantial criteria especially for high speed scanning applications.

The bi-directional gear design makes the system very robust and makes it non-sensitive against external forces.

Mounting Instructions

The system has been developed to be integrated in optical assemblies and for optical benches.

The elements are therefore equipped with a screwing raster (75x25mm, M3 screws) to allow easy mounting on

With its dimensions of 100x34x43,5mm in length, width and height it is universally applicable. The elements of the series PSH 15/1 can be equipped with high resolution measurement systems, which realize a precise position control. Optionally vacuum and cryogenic versions are available.

The components which are to be moved can be clued directly on the top plate (epoxy-glue is recommended) and can be mounted using an adapter plate respectively.



technical data		PSH 15/1
part no.:		K-215-00
active axis		x
tilting angle (open loop)*		$\pm 7.5\text{mrad}$
integrated measurement system		-
resolution**	μrad	0.03
electr. capacitance ($\pm 20\%$)***	μF	3.5
max. load	N	40
tilt @ full motion in y	μrad	23
stiffness	N/ μm	NV
resonant frequency	0g	565Hz
with additional mass of: *	5g	551 Hz
	10g	531 Hz
dimensions	mm	100x34x43,5
weight		300
material		stainless steel / aluminum
connector	voltage	ODU Serie L
	sensor	-
* typ value measured by $-10\dots+150\text{V}$		
** value based on measurement with E-468-011 amplifier		
*** typ. value tolerance of capacitance		

dimensions [mm]

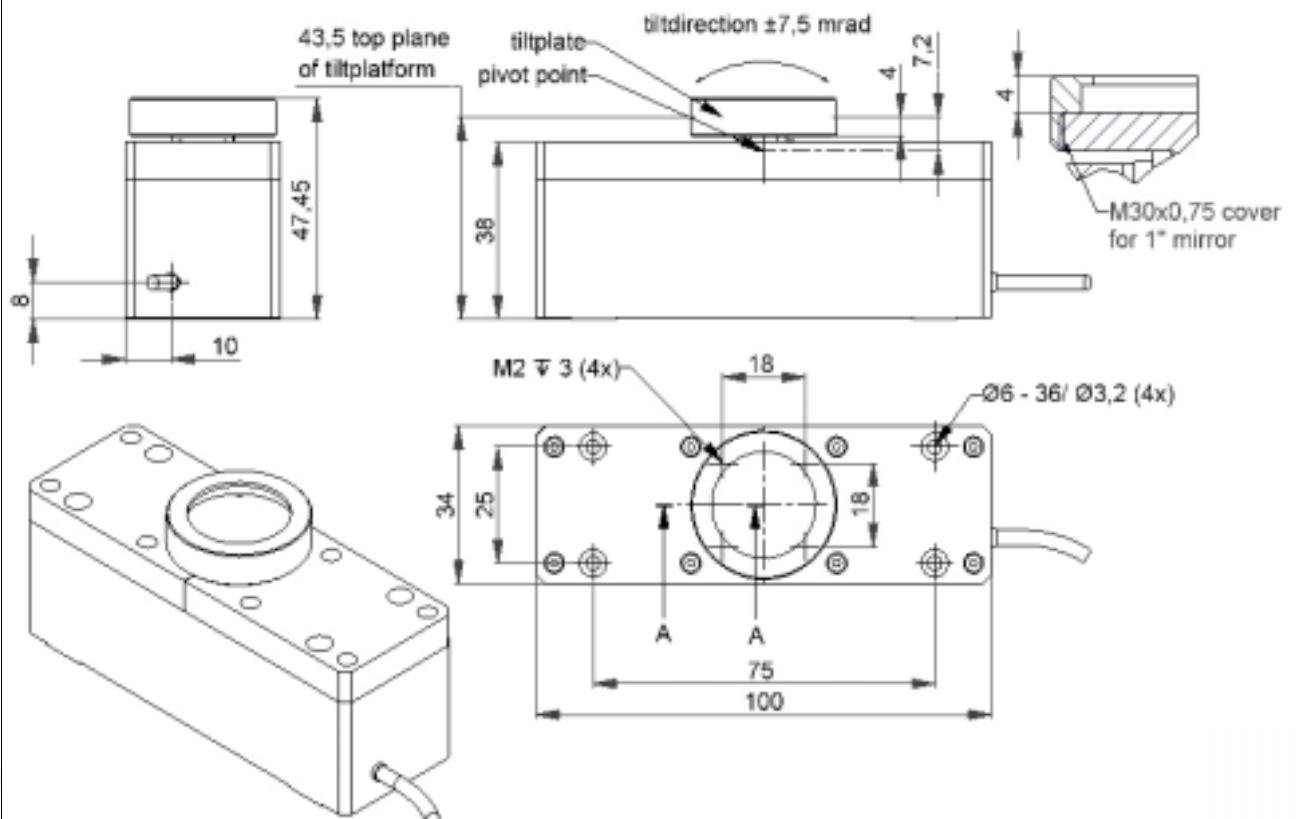

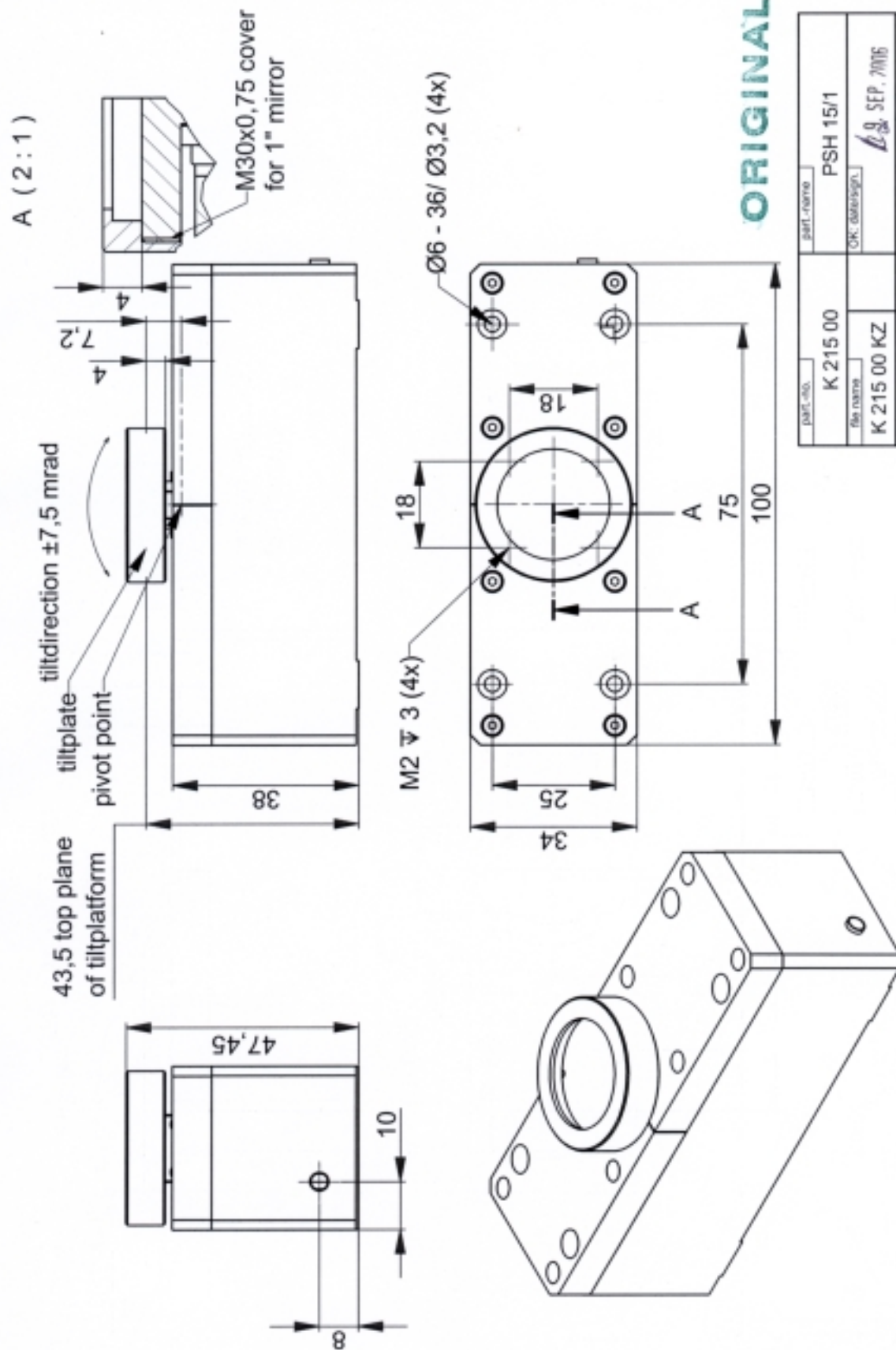

part no.	K 215 00	part name	PSH 15/1
file name	K 215 00 KZ	OK: draught.	B. SEP. 2016
		customers drawing	piezosystem jena
		scale	M 1:1